



High Pressure Water Electrolysis Hydrogen Generation Systems



Main Features

- Bipolar design – compact size
- Low energy consumption of 4.9 kWh/Nm³ of H₂ generated
- Internal gas / lye flow ducts – prevents leakages and hazardous spills
- Automatic and unattended operation.
- Conforms to applicable ASME, IEC, NEC, NFPA standards



Main Features

- Safe operation – failure will always cause the plant to shut down automatically in a controlled manner
- Flexible operation – automatic output control 40 to 100% according to demand
- Easy installation – supplied on skids to minimize installation time and costs



H₂ & O₂ HP. ELECTROLYSIS FLOW DIAGRAM 1

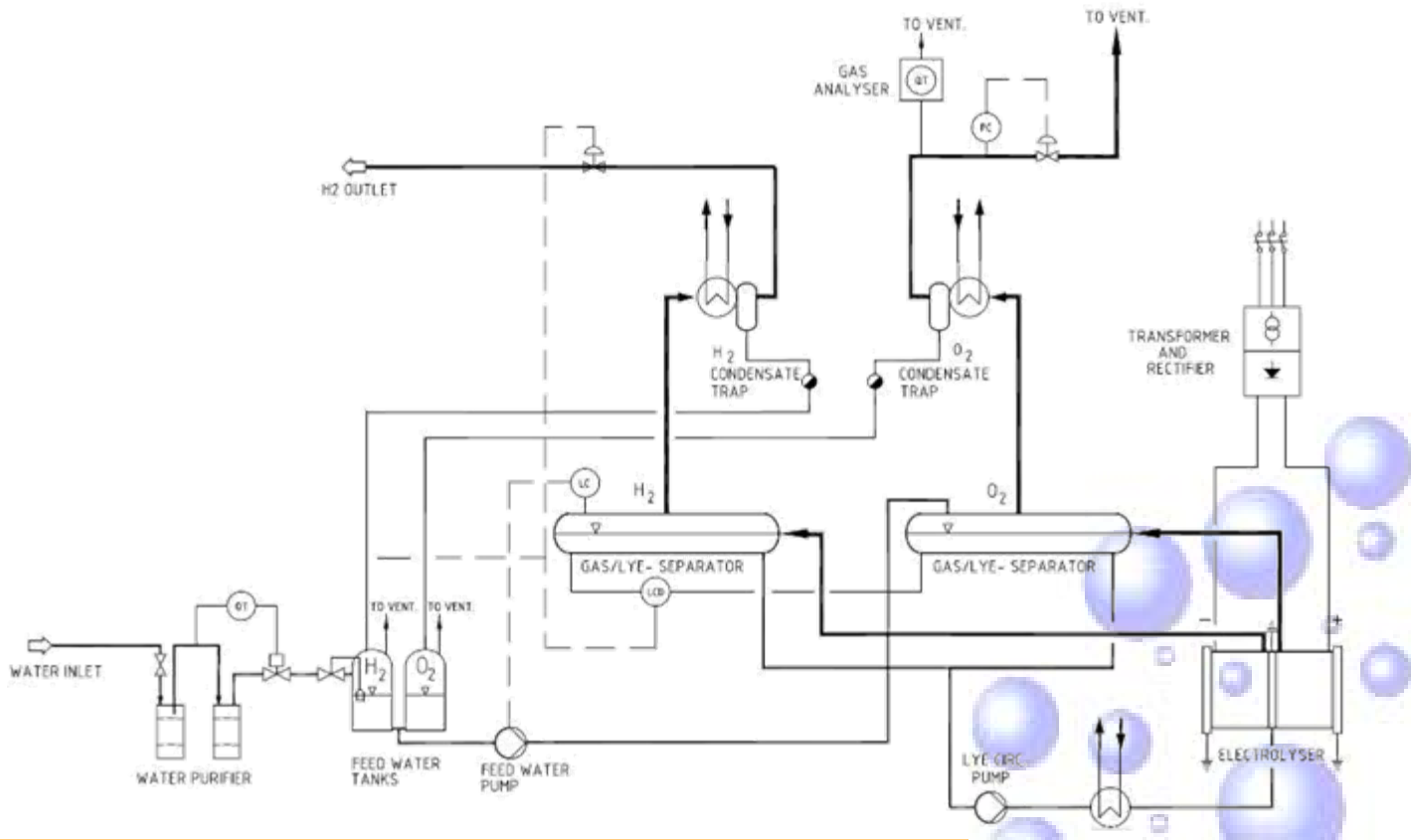

No	Item	series model unit	FDQ5			FDQ10			FDQ20		
			FDQ-2/5.0	FDQ-5/5.0	FDQ-6/5.0	FDQ-8/5.0	FDQ-10/5.0	FDQ-15/5.0	FDQ-20/5.0	FDQ-24/5.0	FDQ-30/5.0
1	H ₂ capacity	Nm ³ /h	2	5	6	8	10	15	20	24	30
2	O ₂ capacity	Nm ³ /h	1	2.5	3	4	5	7.5	10	12	15
3	H ₂ purity	% (v/v)	≥99.9	≥99.9	≥99.9	≥99.9	≥99.9	≥99.9	≥99.9	≥99.9	≥99.9
4	O ₂ purity	% (v/v)	≥99.5	≥99.5	≥99.5	≥99.5	≥99.5	≥99.5	≥99.5	≥99.5	≥99.5
5	H ₂ humidity	g/m ³ H ₂	≤4	≤4	≤4	≤4	≤4	≤4	≤4	≤4	≤4
6	Work pressure*	MPa	5.0	5.0	5.0	5.0	5.0	5.0	5.0	5.0	5.0
7	H ₂ & O ₂ differential pressure	mmH ₂ O	±50	±50	±50	±50	±50	±50	±50	±50	±50
8	Current	A	550	550	550	920	920	920	1670	1670	1670
9	Voltage	V	~18	~42	~50	~38	~50	~74	~54	~66	~82
10	Work temp.	°C	90	90	90	90	90	90	90	90	90
11	Power consumption (DC)	kw · h/m ³ H ₂	≤4.9	≤4.9	≤4.9	≤4.8	≤4.8	≤4.8	≤4.7	≤4.7	≤4.7
12	electrolyte	KOH%	30	30	30	30	30	30	30	30	30
13	Feed water	kg/h	2	5	6	8	10	15	20	24	30
14	Number of cells	Piece	18	42	50	38	50	74	54	66	82

Purity above as measured before purifier. Purity after purifier is < 5ppm O₂

No.	Item	series model unit	FDQ40			FDQ100			FDQ200						
			FDQ-40/5.0	FDQ-50/5.0	FDQ-60/5.0	FDQ-80/3.0	FDQ-100/3.0	FDQ-125/3.0	FDQ-150/3.0	FDQ-175/3.0	FDQ-200/3.0	FDQ-250/3.0	FDQ-300/3.0	FDQ-350/3.0	FDQ-400/3.0
1	H ₂ capacity	Nm ³ /h	40	50	60	80	100	125	150	175	200	250	300	350	400
2	O ₂ capacity	Nm ³ /h	20	25	30	40	50	60.5	75	87.5	100	125	150	175	200
3	H ₂ purity	% (v/v)	≥99.9	≥99.9	≥99.9	≥99.9	≥99.9	≥99.9	≥99.9	≥99.9	≥99.9	≥99.9	≥99.9	≥99.9	≥99.9
4	O ₂ purity	% (v/v)	≥99.5	≥99.5	≥99.5	≥99.5	≥99.5	≥99.5	≥99.5	≥99.5	≥99.5	≥99.5	≥99.5	≥99.5	≥99.5
5	H ₂ humidity	g/m ³ H ₂	≤4	≤4	≤4	≤4	≤4	≤4	≤4	≤4	≤4	≤4	≤4	≤4	≤4
6	Work pressure*	MPa	5.0	5.0	5.0	3.0	3.0	3.0	3.0	3.0	3.0	3.0	3.0	3.0	3.0
7	H ₂ & O ₂ differential pressure	mmH ₂ O	±50	±50	±50	±50	±50	±50	±50	±50	±50	±50	±50	±50	±50
8	Current	A	2480	2480	2480	4600	4600	4600	6600	6600	6600	6600	6600	6600	6600
9	Voltage	V	~74	~94	~110	~76	~98	~122	~102	~122	~138	~170	~206	~242	~274
10	Work temp.	°C	90	90	90	90	90	90	90	90	90	90	90	90	90
11	Power consumption (DC)	kw · h/m ³ H ₂	≤4.6	≤4.6	≤4.6	≤4.5	≤4.5	≤4.5	≤4.4	≤4.4	≤4.4	≤4.4	≤4.4	≤4.4	≤4.4
12	electrolyte	KOH%	30	30	30	30	30	30	30	30	30	30	30	30	30
13	Feed water	kg/h	40	50	60	80	100	125	150	175	200	250	300	350	400
14	Number of cells	Piece	74	94	110	78	98	122	102	122	138	170	206	242	274

Working pressure range from 1 – 3 MPa base on user settable parameters

Typical Electrolysis Cell Design

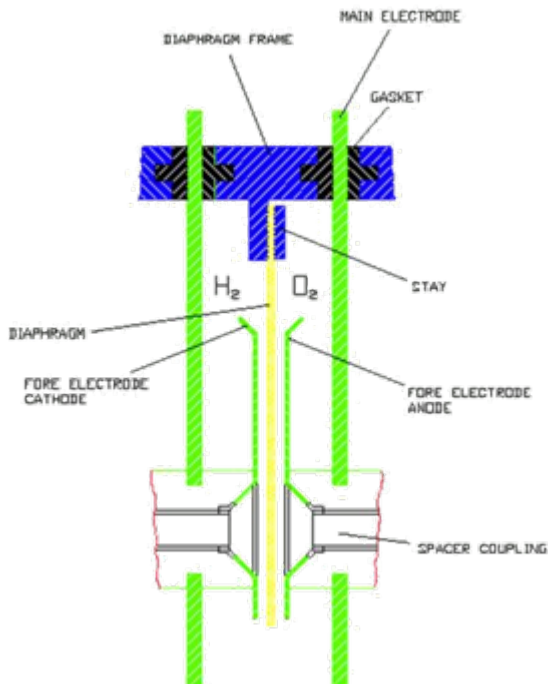

Cell Cross Section

Cell Isometric

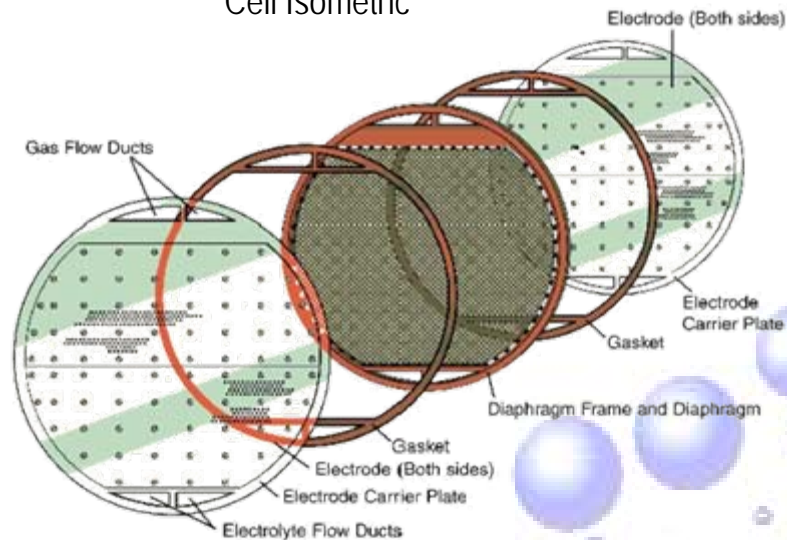

Unique high pressure cell design



Advantages of GasTec high pressure electrolyser design

- Hydrogen compressor is not needed for pressures up to 30 bar.
- Reduced number of rotating equipment – better plant reliability
- Lower maintenance cost
- Low energy consumption – 4.9 kWh/Nm³
- Internal gas / lye flow ducts – preventing leakages and hazardous spills



Automated Control & Plant Monitoring

- GasTec uses Siemens HMI & PLC for fully automated operations

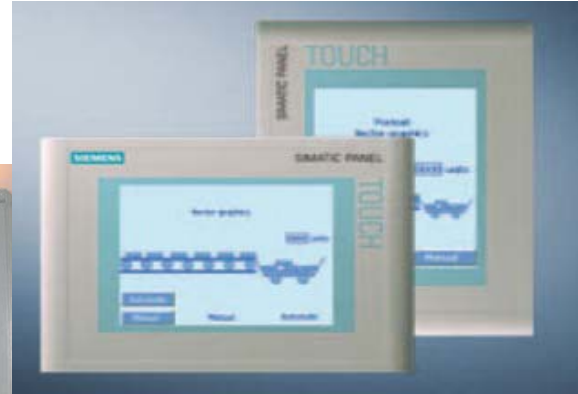

Typical plant installation – Feed water system



Integrated feed water purification system provided with plant.

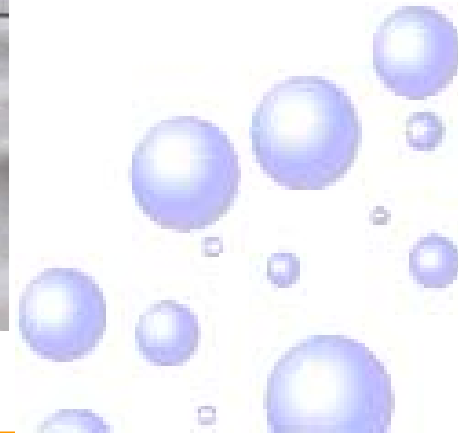

Typical plant installation – Main transformer



Main transformer included with plant.

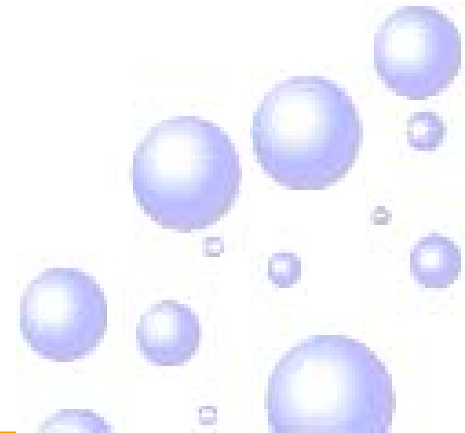

Typical plant installation – Control Panels



Integrated control panels:
Rectifier Panel (Left)
Power Panel (Middle)
PLC Panel (Right)

Typical plant installation – Electrolyser Cells



30 bar High Pressure
electrolysis cell. 10 years
design life span.

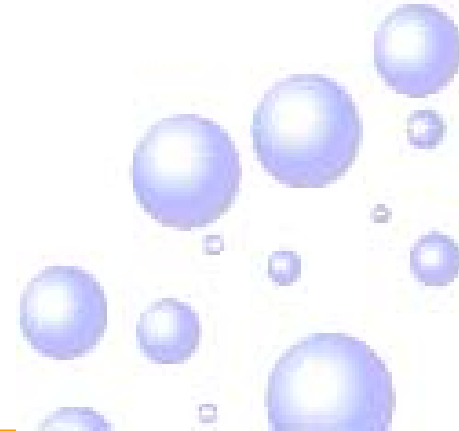

Typical plant installation – Auxiliary Frame Skid



Factory integrated skid containing separators, filters, pumps, transmitters, coolers. All 316L S/S piping & tanks.



Typical plant installation – Purifier Skid



PSA Hydrogen purifier for H₂
purity > 99.999% and -60 °C dew
point

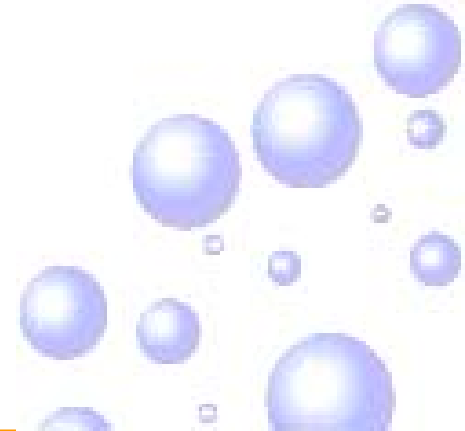

Typical plant installation – Hydrogen Storage



Contact Us:

GAS GENERATORS (MALAYSIA) SDN BHD

8, Jalan P10/21, Taman Industri Selaman
Bandar Baru Bangi, Selangor, Malaysia
Tel: ++603 - 8926 3268 Fax: 603 - 8926 3269

PT GAS GENERATORS INDONESIA

Wisma Tiara Buncit, Jl. Kemang Utara IX no 9 Blok D-12
Jakarta 12760, Indonesia.
Tel. +6221 791 80443, +6221 700 03200
Fax. +6221 791 96532

UNIVERSAL GAS GENERATORS (THAILAND) Co. Ltd.

3/3 Soi Saladaeng Road, Silom, Bangrak,
Bangkok 10500, Thailand
Tel: +66 2233 3546
Fax: +66 2235 5900

GAS GENERATORS (JAPAN) Co. Ltd.

2- Chome, 1-18 Kitayoshizu-Cho
Fukuyama, Hiroshima 720-0073, Japan
Tel +81-84-973-9302
Fax +81-84-926-3367

WWW.GAS TEC.COM.MY
SALES@GAS TEC.COM.MY

